

6" - 300W Professional Woofer

6 NR 2 CP 16 Ω
Code Z004074

GENERAL CHARACTERISTICS		
Nominal Overall Diameter	166	mm
Nominal Voice Coil Diameter	50	mm
Magnet Weight	930	g
Flux Density.....	1.08	T
Weight.....	2.66	Kg

ELECTRICAL CHARACTERISTICS		
Nominal Impedance.....	16	Ω
Musical Power	300	W
Rated Power*	150	W
Sensitivity @ 1 W, 1 m	91.5	dB

THIELE-SMALL PARAMETERS		
Voice Coil DC Resistance	R_E	9.70 Ω
Resonance Frequency	f_s	72.6 Hz
Mechanical Q Factor.....	Q_{MS}	5.57
Electrical Q Factor.....	Q_{ES}	0.49
Total Q Factor	Q_{TS}	0.45
Mechanical Moving Mass	M_{MS}	14.8 g
Mechanical Compliance	C_{MS}	325 μm/N
Force Factor	$B \times l$	11.49 Wb/m
Equivalent Acoustic Volume.....	V_{AS}	6.9 lt.
Maximum Linear Displacement	X_{MAX}	+/-4.0 mm
Reference Efficiency	η_0	0.52 %
Diaphragm Area	S_D	122.7 cm ²
Losses Electrical Resistance.....	R_{ES}	108.9 Ω
Voice Coil Inductance @ 1kHz	L_E	0.72 mH

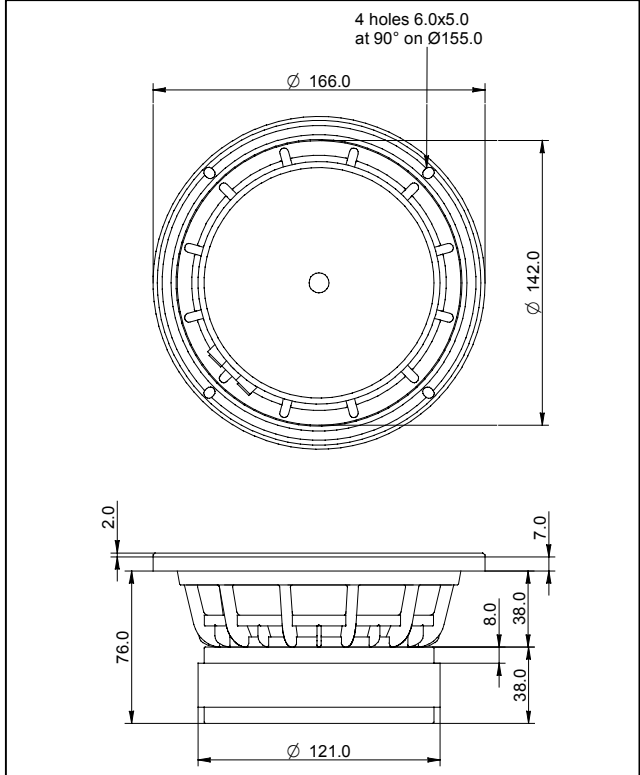

CONSTRUCTIVE CHARACTERISTICS	
Magnet.....	Ferrite
Voice Coil Winding.....	Aluminium
Voice Coil Former.....	Kapton
Cone	Paper
Surround.....	Rubber
Dust Dome	Solid Paper
Basket	Aluminium Die-Cast

*rated power measured with 2 hours test with pink noise signal, 6 dB crest factor, loudspeaker mounted on enclosure
Thiele-Small parameters measured with LASER system

Frequency Response on IEC Baffle (DIN 45575) @ 1 W, 1 m - Free Air Impedance

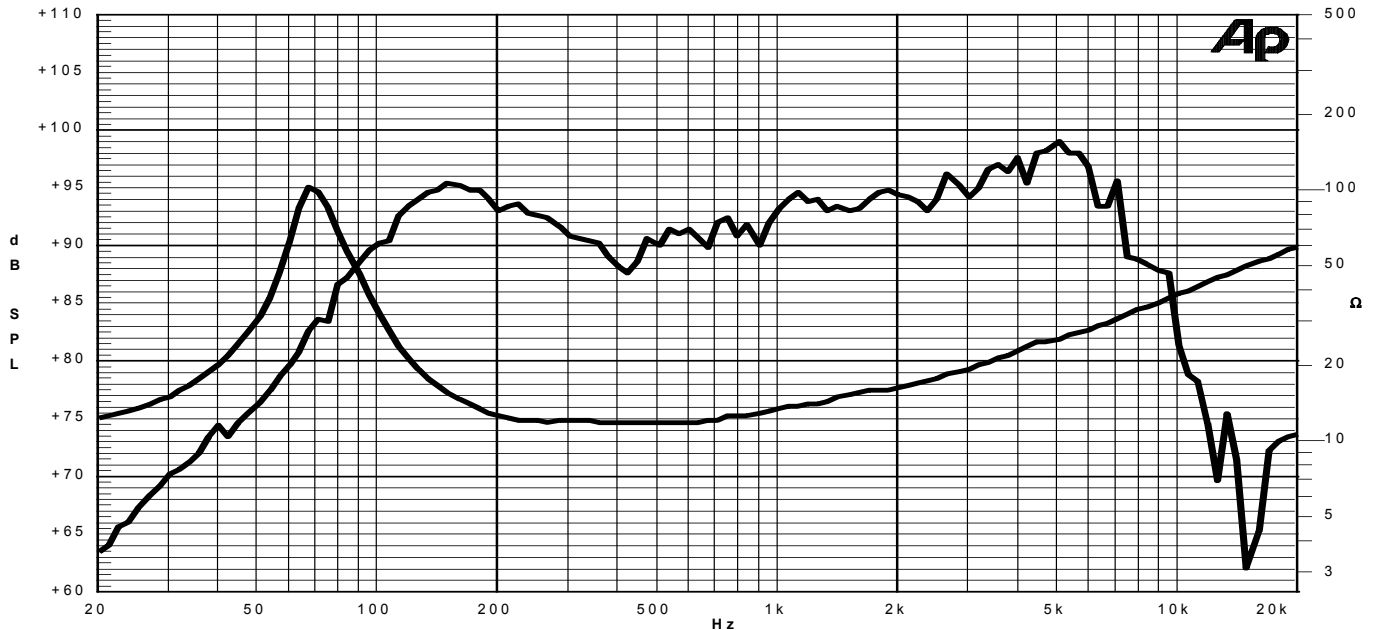

Due to continuing product improvement, the features and the design are subject to change without notice.

20/10/11