

GENERAL CHARACTERISTICS		
Nominal Overall Diameter	165	mm
Nominal Voice Coil Diameter	25	mm
Magnet Weight	270	g
Flux Density.....	1.10	T
Weight.....	0.83	Kg

ELECTRICAL CHARACTERISTICS		
Nominal Impedance.....	4	Ω
Musical Power	120	W
Rated Power*	60	W
Sensitivity @ 1 W, 1 m	90.1	dB

THIELE-SMALL PARAMETERS		
Voice Coil DC Resistance	R_E	3.20 Ω
Resonance Frequency	f_s	82.0 Hz
Total Q Factor	Q_{TS}	0.71
Mechanical Moving Mass	M_{MS}	10.6 g
Mechanical Compliance	C_{MS}	352 μm/N
Force Factor	$B \times l$	4.87 Wb/m
Equivalent Acoustic Volume.....	V_{AS}	7.4 lt.
Maximum Linear Displacement	X_{MAX}	+/-2.0 mm
Diaphragm Area	S_D	123.0 cm ²

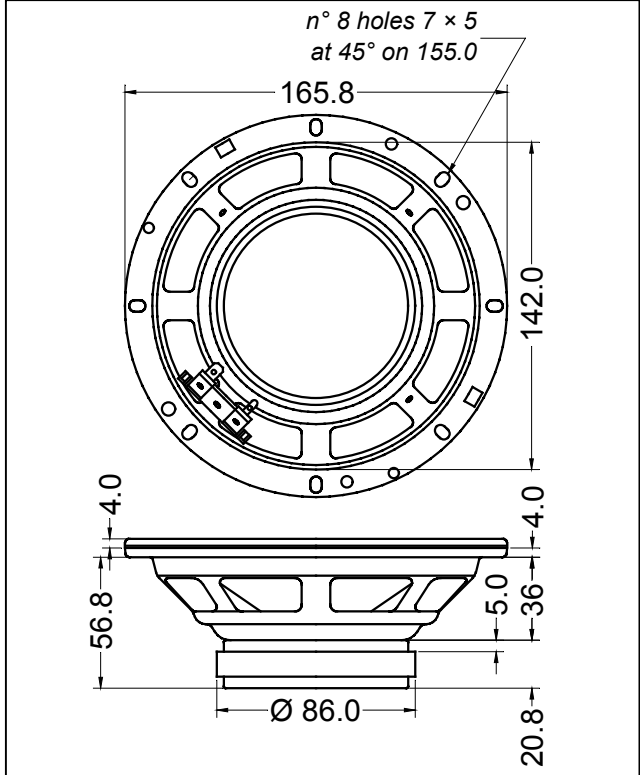

WOOFER CONSTRUCTIVE CHARACTERISTICS	
Magnet.....	Ferrite
Cone	Treated Paper
Surround.....	Rubber
Basket	Pressed Sheet Steel

TWEETER CONSTRUCTIVE CHARACTERISTICS	
Type	Cone Dome
Dome Material.....	Macrofol
Magnet.....	Neodymium
Nominal Radiation Diameter	25 mm
Nominal Voice Coil Diameter	13 mm
Ferrofluid in Air Gap	Yes

*rated power measured with 2 hours test with pink noise signal, 6 dB crest factor, loudspeaker mounted on enclosure

Frequency Response on IEC Baffle (DIN 45575) @ 1 W, 1 m - Impedance

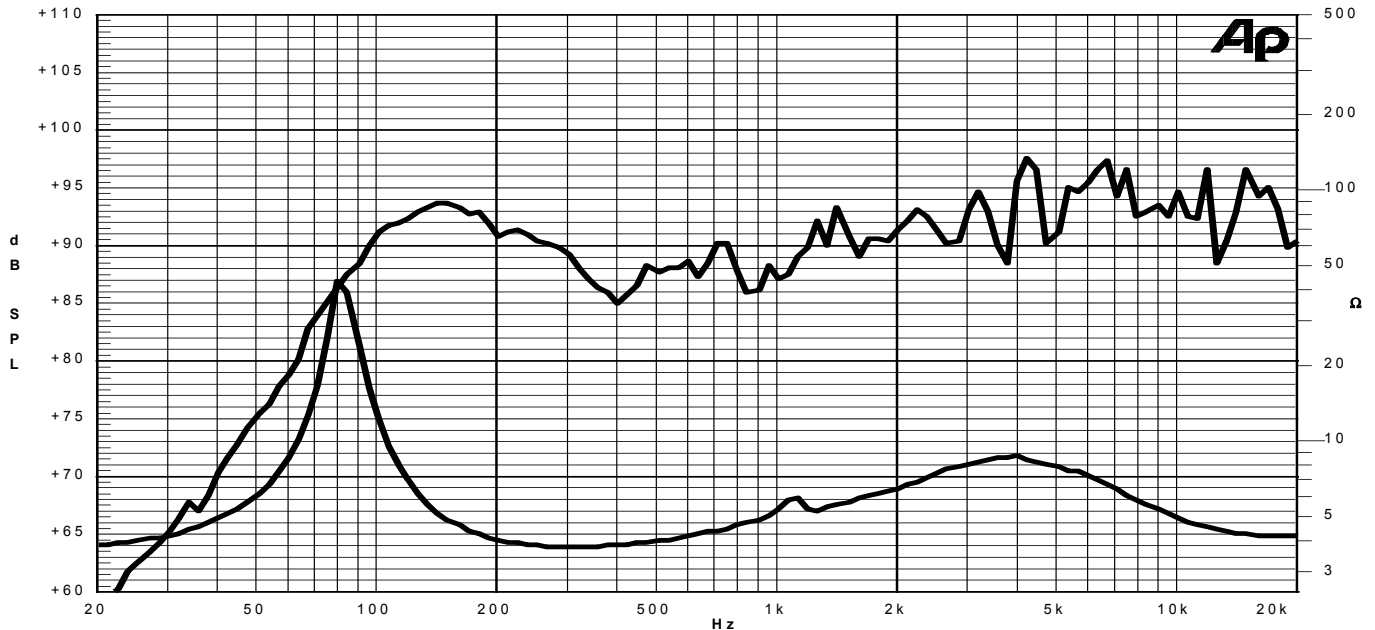

Due to continuing product improvement, the features and the design are subject to change without notice.

09/03/05